

## Chiave combinata

285



FORCHETTA INCLINATA  
con angolo di 15°

SEZIONE A DOPPIA T  
Massima resistenza  
alla flessione



**TOP PERFORMANCE**  
Resistenza alla trazione plastica di acciaio e forchetta  
+50% rispetto alla norma ISO 1711-1

OCCHIO DISASSATO  
per dadi e bulloni rovesciati

## Chiave a cricchetto

285 KA

FORCHETTA CON SISTEMA  
ANTIRITORNAMENTO DEL DADO



ANELLO IN ACCIAIO ARMONICO  
INTEGRATO NELL'OCCHIO  
POLIAGONALE

SEZIONE A DOPPIA T  
Massima resistenza  
alla flessione



**CRICCHETTO RESISTENTE**  
Realizzato in 171mm d'acciaio da cricchetto  
+10% rispetto alla norma ISO 1711-1

usag.it  
YouTube Facebook

285 DS8  
Cil. 8/10/11-12-13-14-15-16-17-18 mm

8 Pezzi Pcs



285 DS12  
Cil. 7-8-10-11-12-13-14-15-16-17-18 mm

12 Pezzi Pcs



285 KF8SS  
Cil. 10-11-12-13-14-17-18 mm

8 Pezzi Pcs



285 KAR512  
Cil. 5/6-10-11-12-13-14-15-16-17-18 mm

12 Pezzi Pcs



## Cricchetto certificato IP51



1. Inclinazione brevettata  
2. Distanza protettiva

## Chiave a rullino

292 CAD

APERTURA  
MAGGIORATA  
+20%



**QUICK ADJUST**

ARRETRÒ E ALLAVIA  
REGOLI RAPIDAMENTE  
MOTO E ALLAVIA  
REGOLI CON PRESSIONE

5 adapters that correspond to the handles of the whole range of screwdrivers 324



34 mm

All the 5 adapters have the same external diameter: they can therefore be freely positioned on the metal shelf



**M0**

**M1**

**M2**

**M3**

**M4**



U05710001

U05710002

U05710003

U05710004

U05710005



Frame the QR code to download the guide with the correspondence between screwdrivers and adapters

## Your exhibitor ready in few steps:



1

Hook the shelf to the wall



2

**0.8x4x100**  
U03240403  
M1

Choose the screwdrivers to be displayed or use one of the front plates supplied

# FOR SCREWDRIVERS

Universal shelf for 70 screwdrivers suitable for display walls and totems

← 480  
↓ 100  
mm ↗ 330



## 6002 EGV

**U60025035Q**

- RAL 9006 painted metal sheet
- 70 seats for adapters 571 B
- Supplied with 2 magnetic hooks
- Including 7 front plates

## The advantages of our solution

Compose your ideal assortment positioning the adapters where you prefer.

System compatible with 091, 322 and 324 screwdrivers.

Change the assortment whenever you want. Adapters are easily removable.



3 Insert the corresponding adapters



4 Place the screwdrivers on the shelf

x100

## 324 RP1 U03240620



Item/size	Pcs.
324 D 0.4x2.5x50	10
324 0.5x3x75	10
324 0.8x4x100	10
324 1x5.5x125	10
324 1.2x6.5x150	10
324 N 0.8x4x35 Corto	10
324 PH 0x75	10
324 PH 1x75	10
324 PH 2x100	10
324 NPH 2x35 Corto	10

x100

## 324 RP2 U03240621



Item/size	Pcs.
324 D 0.4x2.5x50	10
324 0.5x3x75	10
324 0.8x4x100	10
324 1x5.5x125	10
324 1.2x6.5x150	10
324 PH 0x75	10
324 PH 1x75	10
324 PH 2x100	10
324 PZ 1x75	10
324 PZ 2x100	10

x100

## 324 RP3 U03240622



Item/size	Pcs.
324 D 0.4x2.5x50	10
324 0.5x3x75	10
324 D 0.6x3.5x100	10
324 0.8x4x100	10
324 1x5.5x125	10
324 1.2x6.5x150	10
324 1.2x8x200	10
324 1.6x10x200	10
324 N 0.8x4x35 Corto	10
324 N 1x5.5x35 Corto	10

# PROPOSALS



x100

## 324 RP4 U03240623



Item/size	Pcs.
324 D 0.4x2x75	10
324 0.5x3x100	10
324 0.8x4x125	10
324 1x5.5x100	10
324 L 0.6x3.5x250 Lungo	10
324 L 0.8x4x300 Lungo	10
324 L 1x5.5x300 Lungo	10
324 N 1.2x6.5x35 Corto	10
324 E 1.6x10x175 Lama Esag.	10
324 E 2x12x250 Lama Esag.	10



x100

## 324 RP5 U03240624



Item/size	Pcs.
324 PH 0x75	10
324 PH 1x75	10
324 PH 1x100	10
324 PH 2x100	10
324 PH 3x150	10
324 PH 4x200	10
324 LPH 1x250 Lungo	10
324 LPH 2x250 Lungo	10
324 NPH 1x35 Corto	10
324 NPH 2x35 Corto	10



x100

## 324 RP6 U03240625



Item/size	Pcs.
324 PH 0x75	10
324 PH 1x75	10
324 PH 2x100	10
324 PH 3x150	10
324 PH 4x200	10
324 NPH 1x35 Corto	10
324 NPH 2x35 Corto	10
324 PZ 0x75	10
324 PZ 1x75	10
324 PZ 2x100	10



x100

## 324 RP7

U03240626



Item/size	Pcs.
324 TX T6x50	10
324 TX T7x50	10
324 TX T8x50	10
324 TX T9x75	10
324 TX T10x75	10
324 TX T15x75	10
324 TX T20x100	10
324 TX T25x100	10
324 TX T27x100	10
324 TX T30x125	10



x100

## 324 RP8

U03240627



Item/size	Pcs.
324 TX T6x50	10
324 TX T7x50	10
324 TX T8x50	10
324 TX T9x75	10
324 STX T10x75	10
324 STX T15x75	10
324 STX T20x100	10
324 STX T25x100	10
324 STX T27x100	10
324 STX T30x125	10



x100

## 298 RP1

U02980200

Item/size	Pcs.
298 5	10
298 5.5	10
298 6	10
298 7	10
298 8	10
298 9	10
298 10	10
298 11	10
298 12	10
298 13	10



x100

## 299 RP1

U02990300

Item/size	Pcs.
299 4	10
299 5	10
299 5.5	10
299 6	10
299 7	10
299 8	10
299 9	10
299 10	10
299 11	10
299 13	10



# PROPOSALS



x100

## 091 RP1

U00910200

	Item/size	Pcs.
	091 0.4x2.5x75	10
	091 0.5x3x75	10
⊘	091 0.8x4x100	10
	091 1x5.5x125	10
	091 1.2x6.5x150	10
	091 PH 0x75	10
+	091 PH 1x100	10
	091 PH 2x125	10
⊛	091 PZ 1x100	10
	091 PZ 2x125	10



x100

## 091 RP2

U00910201

	Item/size	Pcs.
	091 0.4x2.5x50	10
	091 0.4x2.5x75	10
	091 0.5x3x75	10
	091 0.5x3x100	10
	091 0.6x3.5x75	10
⊘	091 0.6x3.5x100	10
	091 0.8x4x100	10
	091 1x5.5x125	10
	091 1.2x6.5x150	10
	091 1.2x8x150	10



x100

## 091 RP3

U00910202

	Item/size	Pcs.
	091 PH 0x75	10
	091 PH 1x100	10
+	091 PH 2x125	10
	091 PH 3x150	10
	091 DPHB 2x125	10
	091 PZ 0x75	10
	091 PZ 1x100	10
⊛	091 PZ 2x125	10
	091 PZ 3x150	10
	091 DPZB 2x125	10



x100

## 091 RP4

U00910203

**USAG SLIM**

	Item/size	Pcs.
	091 D 0.6x3.5x100	10
⊘	091 D 0.8x4x100	10
	091 D 1x5.5x125	10
	091 D 1.2x6.5x150	10
	091 DPH 1x100	10
	091 DPH 2x125	10
+	091 DPHB 1x100	10
	091 DPHB 2x125	10
⊛	091 DPZB 1x100	10
	091 DPZB 2x125	10



## EXAMPLE OF ASSORTMENT WITH SCREWDRIVERS

COMPLETE KIT - U03240632



x1 **324 RP3**  
**U03240622**  
Shelf for slot-head  
screwdrivers

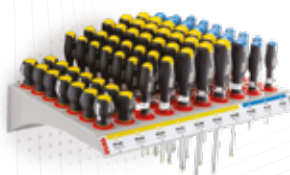

x1 **324 RP6**  
**U03240625**  
Shelf for PHILLIPS®  
screwdrivers

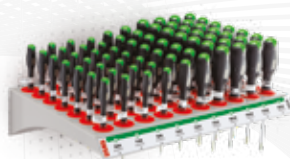

x1 **324 RP7**  
**U03240626**  
Shelf for TORX®  
screwdrivers

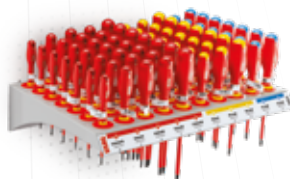

x1 **091 RP1**  
**U00910200**  
Shelf with 1000V  
insulated screwdrivers

Display stand  
**U60000010**



ALSO SUITABLE  
FOR THE TOTEM



Display totem  
**U60025033**

## PAIR OF LIFT FOR DISPLAY STANDS

Transform your shelf into a counter display



### 6002 EGB

U60025038Q

- Pair of metal lift for display stand.

Empty shelf

U60025035Q

### Your exhibitor ready in few steps:

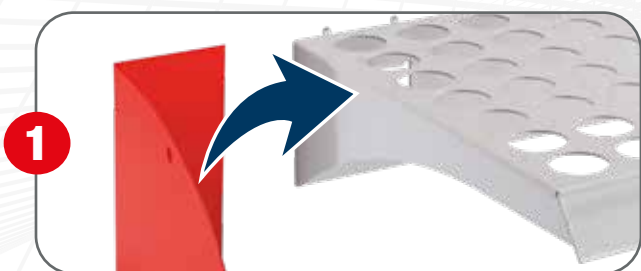

1

Add the lift to the screwdriver shelf



2

Choose the screwdrivers to be displayed or use one of the front plates supplied



3

Insert the corresponding adapters



4

Place the screwdrivers on the shelf

## LAY-OUT PROPOSALS



x100

### 324 RPB2

U03240631



	Item/size	Pcs.
	324 D 0.4x2.5x50	10
	324 0.5x3x75	10
⊘	324 0.8x4x100	10
	324 1x5.5x125	10
	324 1.2x6.5x150	10
	324 PH 0x75	10
+	324 PH 1x75	10
	324 PH 2x100	10
+	324 PZ 1x75	10
	324 PZ 2x100	10

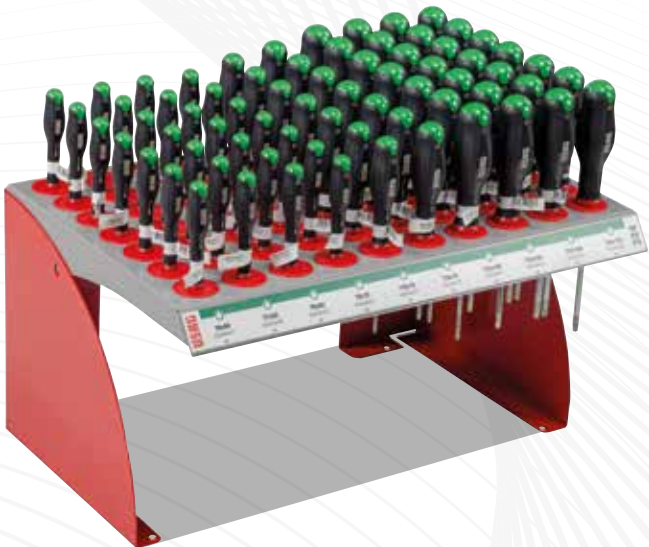

x100

### 324 RPB7

U03240636



	Item/size	Pcs.
	324 TX T6x50	10
	324 TX T7x50	10
	324 TX T8x50	10
	324 TX T9x75	10
+	324 TX T10x75	10
	324 TX T15x75	10
	324 TX T20x100	10
	324 TX T25x100	10
	324 TX T27x100	10
	324 TX T30x125	10

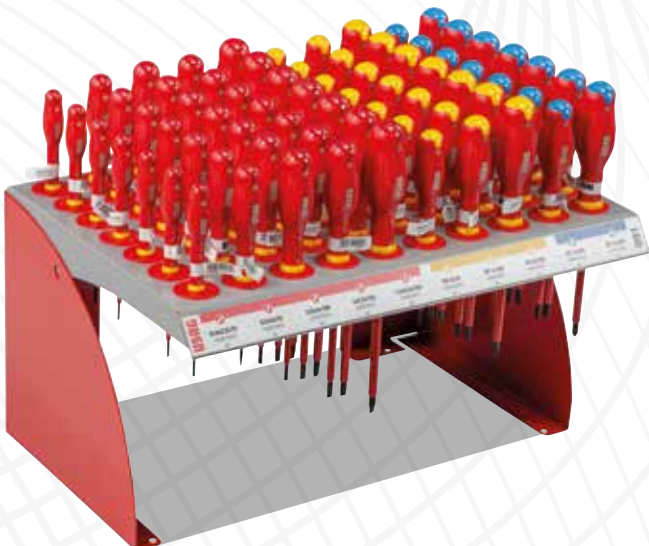

x100

### 091 RPB1

U00910210

	Item/size	Pcs.
	091 0.4x2.5x75	10
	091 0.5x3x75	10
⊘	091 0.8x4x100	10
	091 1x5.5x125	10
	091 1.2x6.5x150	10
	091 PH 0x75	10
+	091 PH 1x100	10
	091 PH 2x125	10
+	091 PZ 1x100	10
	091 PZ 2x125	10

## 5 adapters that correspond to the handles of the whole range of USAG screwdrivers

SCREWDRIVER CODE	ITEM	ADAPTER CODE
U00910003	091 0.4x2.5x50	M0 U05710001
U00910004	091 0.4x2.5x75	M0 U05710001
U00910005	091 0.5x3x75	M1 U05710002
U00910006	091 0.5x3x100	M1 U05710002
U00910007	091 0.6x3.5x75	M1 U05710002
U00910008	091 0.6x3.5x100	M1 U05710002
U00910009	091 0.8x4x100	M2 U05710003
U00910010	091 0.8x4x150	M2 U05710003
U00910011	091 1x5.5x125	M2 U05710003
U00910012	091 1x5.5x150	M2 U05710003
U00910013	091 1.2x6.5x150	M3 U05710004
U00910014	091 1.2x8x150	M4 U05710005
U00910015	091 1.6x10x200	M4 U05710005
U00910023	091 PH 0x75	M1 U05710002
U00910025	091 PH 1x100	M2 U05710003
U00910027	091 PH 2x125	M3 U05710004
U00910029	091 PH 3x150	M4 U05710005
U00910031	091 PH 4x200	M4 U05710005
U00910040	091 PZ 0x75	M1 U05710002
U00910042	091 PZ 1x100	M2 U05710003
U00910044	091 PZ 2x125	M3 U05710004
U00910046	091 PZ 3x150	M4 U05710005
U00910067	091 D 0.6x3.5x100	M1 U05710002
U00910068	091 D 0.8x4x100	M2 U05710003
U00910070	091 D 1x5.5x125	M2 U05710003
U00910072	091 D 1.2x6.5x150	M3 U05710004
U00910085	091 DPH 1x100	M2 U05710003
U00910087	091 DPH 2x125	M3 U05710004
U00910094	091 DPHB 1x100	M2 U05710003
U00910095	091 DPHB 2x125	M3 U05710004
U00910098	091 DPZB 1x100	M2 U05710003
U00910099	091 DPZB 2x125	M3 U05710004
U02430201	243 C 1/4	M2 U05710003
U02430211	243 1/4 SN	M4 U05710005
U02800821	280 D 1.5	M0 U05710001
U02800822	280 D 2	M0 U05710001
U02800823	280 D 2.5	M0 U05710001
U02800824	280 D 3	M0 U05710001
U02800826	280 D 4	M1 U05710002
U02800828	280 D 5	M2 U05710003
U02800830	280 D 6	M3 U05710004
U02800859	280 TS 2	M0 U05710001
U02800860	280 TS 2.5	M0 U05710001
U02800861	280 TS 3	M0 U05710001
U02800863	280 TS 4	M1 U05710002
U02800865	280 TS 5	M2 U05710003
U02800867	280 TS 6	M3 U05710004
U02980251	298 4	M3 U05710004
U02980252	298 5	M3 U05710004
U02980253	298 5.5	M3 U05710004
U02980254	298 6	M3 U05710004
U02980255	298 7	M3 U05710004
U02980256	298 8	M3 U05710004

SCREWDRIVER CODE	ITEM	ADAPTER CODE
U02980257	298 9	M3 U05710004
U02980258	298 10	M4 U05710005
U02980259	298 11	M4 U05710005
U02980260	298 12	M4 U05710005
U02980261	298 13	M4 U05710005
U02980292	298 SN 5.5	M4 U05710005
U02980293	298 SN 6	M4 U05710005
U02980294	298 SN 7	M4 U05710005
U02980295	298 SN 8	M4 U05710005
U02980297	298 SN 10	M4 U05710005
U02980299	298 SN 13	M4 U05710005
U02990201	299 4	M3 U05710004
U02990202	299 5	M3 U05710004
U02990203	299 5.5	M3 U05710004
U02990204	299 6	M3 U05710004
U02990205	299 7	M3 U05710004
U02990206	299 8	M3 U05710004
U02990207	299 9	M3 U05710004
U02990208	299 10	M4 U05710005
U02990209	299 11	M4 U05710005
U02990210	299 12	M4 U05710005
U02990211	299 13	M4 U05710005
U02990212	299 14	M4 U05710005
U03240401	324 0.5x3x75	M0 U05710001
U03240402	324 0.5x3x100	M0 U05710001
U03240403	324 0.8x4x100	M1 U05710002
U03240404	324 0.8x4x125	M1 U05710002
U03240405	324 0.8x4x150	M1 U05710002
U03240406	324 1x5.5x100	M2 U05710003
U03240407	324 1x5.5x125	M2 U05710003
U03240408	324 1x5.5x150	M2 U05710003
U03240409	324 1.2x6.5x125	M3 U05710004
U03240410	324 1.2x6.5x150	M3 U05710004
U03240411	324 1.2x8x200	M4 U05710005
U03240412	324 1.6x10x200	M4 U05710005
U03240413	324 2x12x250	M4 U05710005
U03240419	324 L 0.6x3.5x250	M1 U05710002
U03240420	324 L 0.8x4x300	M1 U05710002
U03240421	324 L 1x5.5x300	M2 U05710003
U03240425	324 D 0.4x2x75	M0 U05710001
U03240426	324 D 0.4x2.5x50	M0 U05710001
U03240427	324 D 0.5x3x75	M0 U05710001
U03240428	324 D 0.6x3.5x100	M1 U05710002
U03240429	324 D 0.8x4x100	M1 U05710002
U03240430	324 D 0.8x4x150	M1 U05710002
U03240431	324 D 1x5.5x125	M2 U05710003
U03240432	324 D 1x5.5x150	M2 U05710003
U03240433	324 D 1.2x6.5x150	M3 U05710004
U03240439	324 PH 0x75	M1 U05710002
U03240440	324 PH 1x75	M2 U05710003
U03240441	324 PH 1x100	M2 U05710003
U03240442	324 PH 2x100	M3 U05710004
U03240443	324 PH 2x125	M3 U05710004

M0



M1



M2



M3



M4



SCREWDRIVER CODE	ITEM	ADAPTER CODE	ADAPTER CODE
U03240444	324 PH 3x150	M4	U05710005
U03240445	324 PH 4x200	M4	U05710005
U03240450	324 LPH 1x250	M2	U05710003
U03240451	324 LPH 2x250	M3	U05710004
U03240452	324 LPH 2X400	M3	U05710004
U03240456	324 PZ 0x75	M1	U05710002
U03240457	324 PZ 1x75	M2	U05710003
U03240458	324 PZ 2x100	M3	U05710004
U03240459	324 PZ 3x150	M4	U05710005
U03240471	324 TX T6x50	M0	U05710001
U03240472	324 TX T7x50	M0	U05710001
U03240473	324 TX T8x50	M0	U05710001
U03240474	324 TX T9x75	M0	U05710001
U03240475	324 TX T10x75	M1	U05710002
U03240476	324 TX T15x75	M2	U05710003
U03240477	324 TX T20x100	M3	U05710004
U03240478	324 TX T25x100	M3	U05710004
U03240479	324 TX T27x100	M3	U05710004
U03240480	324 TX T30x125	M3	U05710004
U03240481	324 TX T40x150	M4	U05710005
U03240486	324 STX T10x75	M1	U05710002
U03240487	324 STX T15x75	M2	U05710003
U03240488	324 STX T20x100	M3	U05710004
U03240489	324 STX T25x100	M3	U05710004
U03240490	324 STX T27x100	M3	U05710004
U03240491	324 STX T30x125	M3	U05710004
U03240492	324 STX T40x150	M4	U05710005
U03240495	324 LTX T20x275	M3	U05710004
U03240496	324 LTX T25x275	M3	U05710004
U03240497	324 LTX T27x275	M3	U05710004
U03240498	324 LTX T30x275	M3	U05710004
U03240499	324 LTX T40x275	M4	U05710005
U03240505	324 E 1x5.5x125	M2	U05710003
U03240506	324 E 1.2x6.5x150	M3	U05710004
U03240507	324 E 1.2x8x175	M4	U05710005
U03240509	324 E 1.6x10x175	M4	U05710005
U03240510	324 E 2x12x250	M4	U05710005
U03240513	324 EPH 1x100	M2	U05710003
U03240514	324 EPH 2x125	M3	U05710004
U03240515	324 EPH 3x150	M4	U05710005
U03240516	324 EPH 4x200	M4	U05710005
U03240520	324 EPZ 2x125	M3	U05710004
U03240521	324 EPZ 3x150	M4	U05710005
U03240522	324 EPZ 4x200	M4	U05710005
U03240533	324 H 0.8x4x100	M1	U05710002
U03240534	324 H 1x5.5x125	M2	U05710003
U03240535	324 H 1.2x6.5x150	M3	U05710004
U03240536	324 H 1.2x8x175	M4	U05710005
U03240537	324 H 1.6x10x175	M4	U05710005
U03240538	324 H 2x12x200	M4	U05710005
U03240539	324 H 2.5x14x250	M4	U05710005
U03240541	324 HPH 1x100	M2	U05710003

SCREWDRIVER CODE	ITEM	ADAPTER CODE	ADAPTER CODE
U03240542	324 HPH 2x125	M3	U05710004
U03240543	324 HPH 3x150	M4	U05710005
U03240463	324 N 0.8x4x35	M0	U05710001
U03240464	324 N 1x5.5x35	M1	U05710002
U03240465	324 N 1.2x6.5x35	M2	U05710003
U03240468	324 NPH 1x35	M0	U05710001
U03240469	324 NPH 2x35	M2	U05710003
U06900102	690 A 1/4 180	M3	U05710004
U06900103	690 A 1/4 245	M3	U05710004
U03220025	322 0.4x2x50	M1	U05710002
U03220005	322 0.4x2.5x75	M1	U05710002
U03220006	322 0.5x3x75	M1	U05710002
U03220007	322 0.6x3.5x100	M1	U05710002
U03220028	322 0.6x3.5x75	M2	U05710003
U03220008	322 0.8x4x100	M2	U05710003
U03220009	322 0.8x4x125	M3	U05710004
U03220011	322 1x5.5x100	M2	U05710003
U03220012	322 1x5.5x125	M3	U05710004
U03220014	322 1.2x6.5x125	M4	U05710005
U03220015	322 1.2x6.5x150	M4	U05710005
U03220017	322 1.6x8x175	M4	U05710005
U03220023	322 1.6x10x200	M4	U05710005
U03220024	322 2x12x250	M4	U05710005
U03220039	322 PH 0x75	M2	U05710003
U03220041	322 PH 1x100	M3	U05710004
U03220043	322 PH 2x125	M3	U05710004
U03220047	322 PH 3x150	M4	U05710005
U03220056	322 PZ 0x75	M2	U05710003
U03220057	322 PZ 1x100	M3	U05710004
U03220058	322 PZ 2x125	M3	U05710004
U03220063	322 N 0.8x4x30	M0	U05710001
U03220064	322 N 1x5.5x30	M1	U05710002
U03220065	322 N 1.2x6.5x30	M2	U05710003
U03220068	322 NPH 1x30	M0	U05710001
U03220069	322 NPH 2x30	M2	U05710003
U03220071	322 TX T6x50	M1	U05710002
U03220072	322 TX T7x50	M1	U05710002
U03220073	322 TX T8x50	M1	U05710002
U03220074	322 TX T9x75	M1	U05710002
U03220075	322 TX T10x75	M2	U05710003
U03220076	322 TX T15x75	M2	U05710003
U03220077	322 TX T20x100	M2	U05710003
U03220078	322 TX T25x100	M3	U05710004
U03220079	322 TX T27x100	M3	U05710004
U03220080	322 TX T30x125	M4	U05710005
U03220081	322 TX T40x125	M4	U05710005
U03220086	322 STX T10x75	M2	U05710003
U03220087	322 STX T15x75	M2	U05710003
U03220088	322 STX T20x100	M2	U05710003
U03220089	322 STX T25x100	M2	U05710003
U03220090	322 STX T27x100	M2	U05710003
U03220091	322 STX T30x125	M2	U05710003
U03220092	322 STX T40x125	M2	U05710003

## SHELVES FOR SOCKET WRENCHES IN BI-COLOUR FOAM MODULE

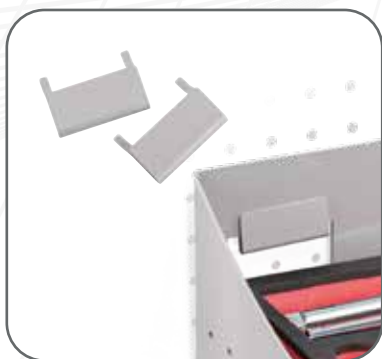

Hooks with magnet: you can easily position and remove the shelf also when it is full



Side step drilling 25 mm to be able to attach other products.



Bi-colour foam with measurement markings. Find the product easily.

x239

## 235 RP1 U02351500



### Shelf with sockets

Description	Item/size	Pcs.
Long hexagonal sockets// 4-4,5-5-5,5-6-7-8-9-10-11-12-13-14	235 1/4 EL	78
Hexagonal sockets / 4-4,5-5-5,5-6-7-8-9-10-11-12-13-14	235 1/4 EN	130
Extensions/50-100-150	236 1/4	15
T-handle with sliding square drive	240 1/4	5
Universal joint	241 1/4	6
Spinner with handle	243 1/4	5

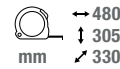

x150

## 235 RP2 U02351501



### Shelf with sockets

Description	Item/size	Pcs.
Hexagonal sockets / 8-9-10-11-12-13-14-15-16-17-18-19-20-21-22	235 1/2 EN	150

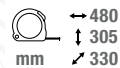

x56

## 235 RP3 U02351502



### Shelf with sockets

Description	Item/size	Pcs.
Hexagonal sockets / 23-24-25-26-27-28-30-32	235 1/2 EN	40
Extensions/125-250	236 1/2	10
Universal joint	241 1/2	6

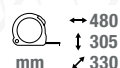

## XGRIP



x122

**235 RP6**  
U02351505



Shelf with special profile sockets

Description	Item/size	Pcs.
Hexagonal sockets with special profile X-Grip / 5,5-6-7-8-9-10-11-12-13-14	235 X 1/4	50
Hexagonal sockets with special profile X-Grip / 10-11-12-13-14-15-16-17-18-19-22-24	235 X 1/2	58
Long hexagonal sockets with special profile X-Grip / 17-19-21	235 XL 1/2	14

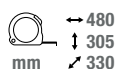

x120

**235 RP4**  
U02351503



Shelf with impact sockets

Description	Item/size	Pcs.
Impact hexagonal sockets / 8-9-10-11-12-13-14-15-16-17-18-19-20-21-22	235 1/2 M	120



x50

**235 RP5**  
U02351504



Shelf with impact sockets

Description	Item/size	Pcs.
Impact hexagonal sockets / 23-24-27-30-32-36	235 1/2 M	30
Long impact hexagonal sockets / 13-17-19-24	235 1/2 ML	20

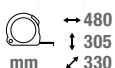



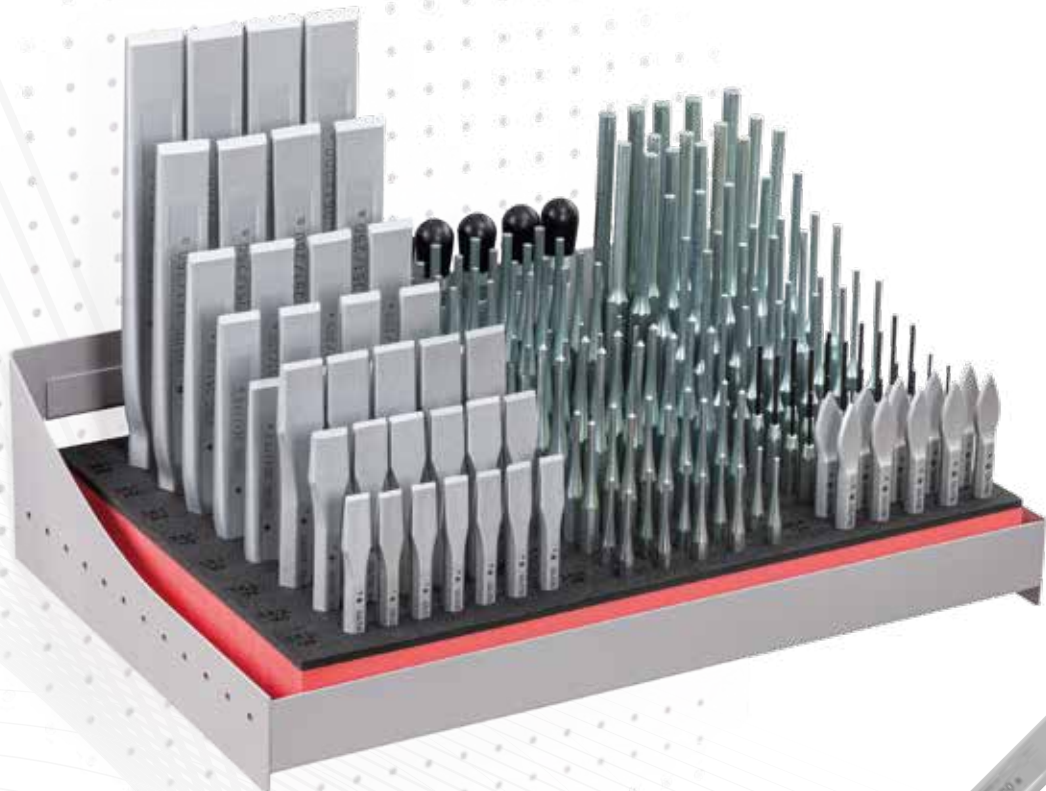

**x220** **351 RP1**  
**U03510050**

Shelf with chisels and punches

Description	Item/size	Pcs.
Ribbed chisels/ 150-175-200-250-300	351	25
Chisels/ 125-150-175	362	30
Cross cut chisel	364/125	10
Drift punches/ 2x125-3x125-4x150-5x150-6x150	366	50
Pin punches/ 2x115-3x125-4x145-5x165-6x180-8x200-10x210	367	70
Centre punches/ 3x100-4x125-5x150	368	30
Automatic centre punch	368 B	5

→ 480  
 ↓ 305  
 mm ↗ 330





x20

## 150 AX/SH20

U01500260

Multiple display hook

Description	Item/size	Pcs.
Half-round extra-long nose pliers with straight jaws	133 AX 160	5
Combination pliers	150 AX 180	5
Diagonal cutting nippers	185 AX 160	5
Heavy-duty diagonal cutting nippers	188 AX 160	5

Empty display hook  
U01500260Q



x20

## 085 EX/SH20

U00850260

Multiple display hook

Description	Item/size	Pcs.
Half-round extra-long nose pliers with straight jaws	081 EX 160	5
Combination pliers	085 EX 180	5
Diagonal cutting nippers	087 EX 160	5
Heavy-duty diagonal cutting nippers	088 EX 160	5

Empty display hook  
U01500260Q



x8

## 134 A/B8

U01340010

Counter display stand with grip pliers

Description	Item/size	Pcs.
Lock-grip pliers with concave jaws	134 A/250	2
Lock-grip rack-type pliers with short jaws	135 A/250	2
Lock-grip rack-type pliers with long jaws	135 B/250	2
Lock-grip rack-type pliers with high capacity	135 C/250	2

↔ 260  
↑ 360  
mm ↘ 153



x20

## 127 N/SH20

**U01270041**

Multiple display hook

Description	Item/size	Pcs.
Pliers with straight nose for internal circlips	127 N 19÷60	5
Pliers with nose bent at 90° for internal circlips	127 PN 19÷60	5
Pliers with straight nose for external circlips	128 N 19÷60	5
Pliers with nose bent at 90° for external circlips	128 PN 19÷60	5

**Empty display hook  
U01500260Q**



x20

## 127 C/SH20

**U01270042**

Multiple display hook

Description	Item/size	Pcs.
Pliers with straight nose for internal circlips	127 C 19÷60	5
Pliers with nose bent at 90° for internal circlips	127 CP 19÷60	5
Pliers with straight nose for external circlips	128 C 19÷60	5
Pliers with nose bent at 90° for external circlips	128 CP 19÷60	5

**Empty display hook  
U01500260Q**



x20

## 178 N/SH20

**U01780260**

Multiple display hook

Description	Item/size	Pcs.
Lay-on slip-joint adjustable pliers	178 N 250	5
Box-joint adjustable pliers	180 C 250	5
Semiautomatic adjustable pliers	180 B 250	5
Long nose semiautomatic adjustable pliers	180 BL 250	5

**Empty display hook  
U01500260Q**

# EXAMPLE OF LAY OUT FOR AIRTOOLS

COMPLETE KIT - U60025030



x1

**6002 VP**

**U60025026**

Advertising top

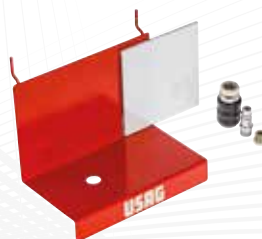

x10

**571 GP**

**U60025024**

Exhibition hook



x26

**571 CD**

**U60025027**

Technical cards



x1

**6002 MP**

**U60025025**

Magnetic  
product cards

Display wall  
**U60000010**

## METAL COUNTER DISPLAY STANDS



x1

### 943 PC1/S1

**U60025017**

Counter display stand with impact wrench

Description	Item/size	Pcs.
Magnesium impact wrench with LED	943 PC1 1/2"	1

**Empty display stand  
U60025023**



x3

### 928 A1/S3

**U09280103**

Counter display stand with impact wrenches

Description	Item/size	Pcs.
Magnesium impact wrench with LED	943 PC1 1/2"	1
Magnesium impact wrench	929 PC1 1/2"	1
Aluminium impact wrench	928 AC1 1/2"	1

**Empty display stand  
U09280001Q**

## TOTEM FOR SOFT BAG



Side 1



Side 2

x29

### 007 T29

U00070100

Soft storage display

Description	Item/size	Pcs.
Professional tool bag	007/1V	2
Professional tool bag	007 V	2
Trolley tool bag	007 TXV	2
Folding tool bag	007 FLV	1
Folding tool bag	007 FTSV	1
Tool-holding pouch	007 MV	4

Description	Item/size	Pcs.
Tool-holding pouch with belt	007 MLV	2
Organizer	007 ORV	4
Laptop bag	007 PCV	4
Bag for laptop and tools	007 RV	3
Professional backpack	007 SV	2
Professional tool trolley	007 TV	2

**EMPTY TOTEM DISPLAY**  
U60025033

**EMPTY SHELF**  
U60025037Q

## BITS DISPLAY



product data

x600



### 660 B600

U06600600

Bits display

Item/size	Pcs.	Item/size	Pcs.
660 E 1,5	10	660 TX T10	20
660 E 2	30	660 TX T15	20
660 E 2,5	30	660 TX T20	30
660 E 3	30	660 TX T25	20
660 E 4	30	660 TX T27	10
660 E 5	30	660 TX T30	30
660 E 6	30	660 TX T40	20
660 E 7	10	660 TX T6	10
660 E 8	10	660 TX T7	10
660 PH 0	10	660 TX T8	10
660 PH 1	30	660 TX T9	10
660 PH 2	30	660 0,5x4	10
660 PH 3	20	660 0,8x5,5	10
660 PZ 1	30	660 1,2x6,5	10
660 PZ 2	30		
660 PZ 3	20		



 → 430  
 ↓ 1130  
 mm  ↗ 370

## PALL BOX 324

Ready to be displayed in a few simple steps!

Assembly instructions

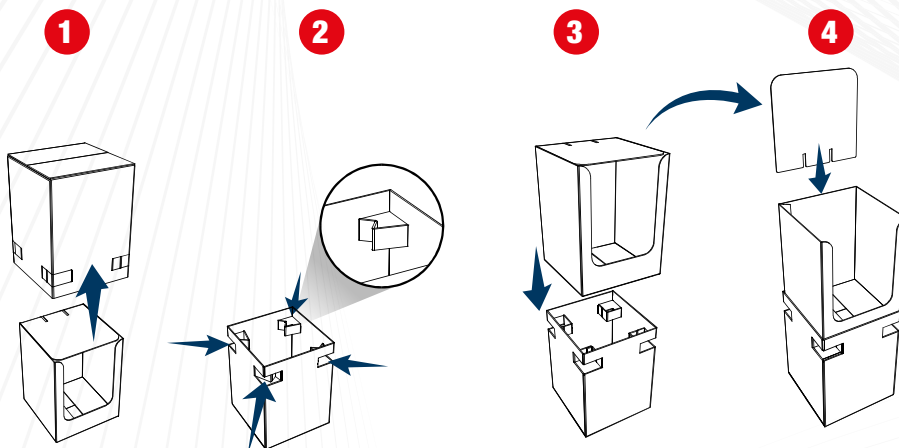

x20

### 324 SH8/PB20

**U03240600**

Pallbox with 20 sets  
of screwdrivers  
U03240650



x20

### 324 SH12/PB20

**U03240601**

Pallbox with 20 sets  
of screwdrivers  
U03240651







→ 370  
 ↑ 980  
 ↗ 370  
 mm

## UNIVERSAL PALLBOX

Ready to be displayed in a few simple steps!

Assembly instructions

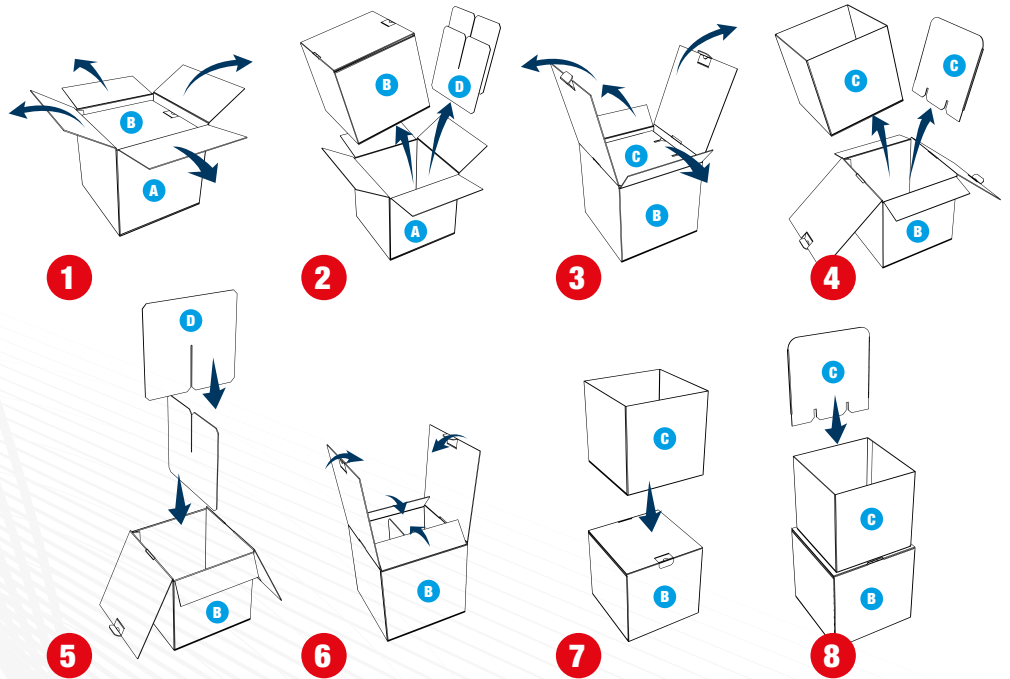

**x30 322 SH5/PB30**

**U03220333**

Pallbox with 30 sets  
of screwdrivers  
U03220253



**x16 322 SH7/PB16**

**U03220330**

Pallbox with 16 sets  
of screwdrivers  
U03220254





x10

## 324 STX7/PB10

U03240602

Pallbox with 10 sets  
of screwdrivers  
U03240662



x14

## 091 PB14

U00910130

7 sets U00910100  
7 sets U00910119



x16

## 322 SH10/PB16

U03220331

Pallbox with 16 sets  
of screwdrivers  
U03220255



x30

## 280 S8/PB30

U02800492

Pallbox with 30 sets  
of hexagon keys  
U02800192



x30

## 280 LTS/S9PB30

U02800484

Pallbox with 30 sets of long  
angled hexagon keys with  
spherical head  
U02800084





x40 **280 S9/PB40**

**U02800387**

Pallbox with 40 sets of angled hexagon keys - U02800287



x100 **220 B1/PB100**

**U02200101**

Pallbox with 100 utility knives - U02200001



x50 **207 C/PB50**

**U02070104**

Pallbox with 50 scissors for electricians U02070004



x30 **211 A/PB30**

**U02110101**

Pallbox with 30 multipurpose scissors U02110001



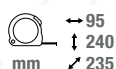

x5

## 133 AX/B5

**U01330250**

Supplied with 5 half-round extra-long nose pliers with straight jaws - U01330150 (180 mm)



x5

## 133 DX/B5

**U01330256**

Supplied with 5 pliers U01330174 (160 mm)

x5

## 133 AX/B5L

**U01330251**

Supplied with 5 half-round extra-long nose pliers with straight jaws - U01330151 (200 mm)



x5

## 133 DX/B5L

**U01330257**

Supplied with 5 pliers U01330175 (200 mm)

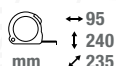

x5

## 150 AX/B5

**U01500251**

Supplied with 5 combination pliers - U01500151 (180 mm)



x5

## 150 DX/B5

**U01500259**

Supplied with 5 pliers U01500177 (180 mm)

x5

## 150 AX/B5L

**U01500252**

Supplied with 5 combination pliers - U01500152 (200 mm)



x5

## 150 DX/B5L

**U01500264**

Supplied with 5 pliers U01500178 (200 mm)

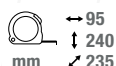

x5

## 185 AX/B5

**U01850252**

Supplied with 5 diagonal cutting nippers - U01850152 (160 mm)



x5

## 185 DX/B5

**U01850260**

Supplied with 5 nippers U01850178 (160 mm)

x5

## 188 AX/B5

**U01880251**

Supplied with 5 heavy-duty diagonal cutting nippers U01880151 (160 mm)



x5

## 188 DX/B5

**U01850261**

Supplied with 5 nippers U01880179 (160 mm)

## STANDS IN CARDBOARD



x10

### 150 AX/B10

**U01501151**

Supplied with 10 combination pliers U01500151 (180 mm)

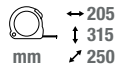

x10

### 150 DX/B10

**U01500358**

Supplied with 10 pliers U01500177 (180 mm)

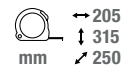

x5

### 178 N/B5

**U01780013**

Supplied with 5 lay-on slip-joint adjustable pliers U01780012 (250 mm)

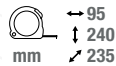

x5

### 180 C/B5

**U01800013**

Supplied with 5 box-joint adjustable pliers U01800010 (250 mm)

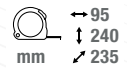

x5

### 155 AX/B5

**U01550253**

Supplied with 5 pliers U01550001

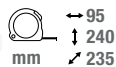

x5

### 174 CX/B5

**U01740101**

Supplied with 5 plier wrenches U01740001





x10

## 207 C/B10

**U02070014**

Supplied with 10  
scissors - U02070004

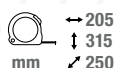

x6

## 207 D/B6

**U02070108**

Supplied with 6  
scissors - U02070008

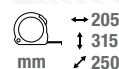

x6

## 207 E/B6

**U02070106**

Supplied with 6  
scissors - U02070006

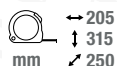

x5

## 280 LTS/B5

**U02800384**

Supplied with 5 sets of  
long angled hexagon  
keys with spherical head  
U02800084

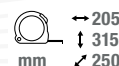

x5

## 280 S9/B5

**U02800187**

Supplied with 5 sets of  
angled hexagon keys  
U02800287

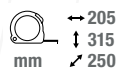

x5

## 280 NS9/B5

**U02800831**

Supplied with 5 sets of  
angled hexagon keys  
U02800731

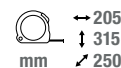



x5

## 280 TX/B5

**U02800676**

Supplied with 5 sets of keys for TORX® screws U02800576

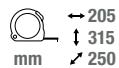

x8

## 280 XLTSS9/B8

**U02800385**

Supplied with 8 sets of hexagon keys U02800184

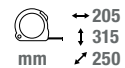

x8

## 283 SE5/B8

**U02831420**

Supplied with 8 sets with double ended offset bihexagonal ring wrenches U02831402

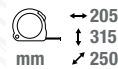

x8

## 285 SE5/B8

**U02850880**

Supplied with 8 sets of 5 combination wrenches U02850858

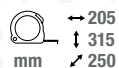

x8

## 285 PSE5/B8

**U02850881**

Supplied with 8 sets of combination wrenches U02850856

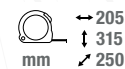

x8

## 285 KASE5/B8

**U02856090**

Supplied with 8 sets of reversible ratchet combination wrenches U02856074

↔ 205  
↓ 315  
mm ↗ 250



x8

## 285 KBSE5/B8

**U02856390**

Supplied with 8 sets of flat ratchet combination wrenches U02856338

↔ 205  
↓ 315  
mm ↗ 250



x8

## 285 KFSE5/B8

**U02856190**

Supplied with 8 sets of hinged jointed reversible ratchet combination wrenches U02856160

↔ 205  
↓ 315  
mm ↗ 250



x8

## 289 NSE5/B8

**U02890290**

Supplied with 8 sets of double ended offset tubular box wrenches U02890280

↔ 205  
↓ 315  
mm ↗ 250



x8

## 291 NSE5/B8

**U02910290**

Supplied with 8 sets with double ended hollow offset socket wrenches U02910280

↔ 205  
↓ 315  
mm ↗ 250



x5

## 294 AC/B5

**U02940110**

Supplied with 5 short adjustable wrenches U02940010

↔ 205  
↓ 315  
mm ↗ 250





## STANDS IN CARDBOARD



x5

### 324 SH5/B5

**U03240610**

Supplied with 5 set of screwdrivers U03240645

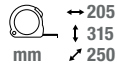

x5

### 341 SH17/B5

**U03410116**

Supplied with 5 sets of precision screwdrivers with interchangeable blades - U03410016

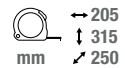

x5

### 341 SH4TX/B5

**U03410117**

Supplied with 5 sets of precision screwdrivers for TORX® screws U03410017

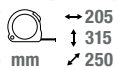

x5

### 341 SH6/B5

**U03410118**

Supplied with 5 sets of precision screwdrivers U03410018

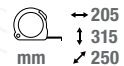

x5

### 341 SH33/B5

**U03410119**

Supplied with 5 sets of bit-holder precision screwdrivers and bits U03410019

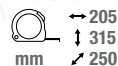



x4

## 601 J34/B4

**U06010002**

Supplied with 4 assortments of sockets - U06010001

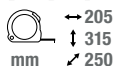

x4

## 601 JTX16/B4

**U06010019**

Supplied with 4 assortments of sockets - U06010009

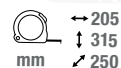

x10

## 692 J49/B10

**U06920141**

Supplied with 10 boxes with bits and accessories U06920041

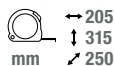

x5

## 889 TM/B5

**U08890124**

Supplied with 5 Pen-type LED torch U08890071

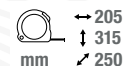



x4

## 235 1/2" MBC10/B4

**U02351530**

Supplied with 4 assortments of sockets U02350530

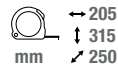

x4

## 270 CC3/B4

**U02700107**

Supplied with 4 assortments of sockets U02700106

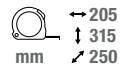

x20

## 220 A1/B20

**U02200013**

Supplied with 20 utility knives - U02200000

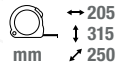

x20

## 220 B1/B20

**U02200014**

Supplied with 20 utility knives - U02200001

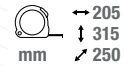

x8

## 333 K SH8/B8

**U03330150**

Supplied with 8 assortments COMBIDRIVE U03330142

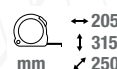



→ 1000  
↓ 2500  
mm ↗ 500

## 6000 A

**U60000008**

Display stand, initial element

- Supplied with light and USAG top
- Kit with 78 hooks and supports included
- 2 uprights included



→ 1087  
↓ 2500  
mm ↗ 500

## 6000 B

**U60000012**

Display stand, closed corner

- Supplied with light and USAG top
- Kit with 78 hooks and supports included
- Structure without uprights



→ 900  
↓ 2060  
mm ↗ 500

## 6000 C

**U60000013**

Display stand, open corner

- Non-perforated panels
- Structure without uprights



→ 1000  
↓ 2500  
mm ↗ 500

## 6000 D

**U60000014**

Display stand, back for initial element

- Supplied with light and USAG top
- Kit with 78 hooks and supports included
- Structure without uprights

## AND ACCESSORIES

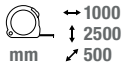

### 6000 AS

**U60000011**

Display stand,  
consecutive element

- Supplied with light and USAG top
- Kit with 78 hooks and supports included
- 1 upright included

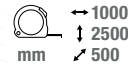

### 6000 DS

**U60000015**

Display stand, back for  
consecutive element

- Supplied with light and USAG top
- Kit with 78 hooks and supports included
- Structure without uprights



### 6001 A

**U60010010**

Display stand, initial  
element

- Kit with 78 hooks and supports included
- 2 uprights included

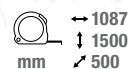
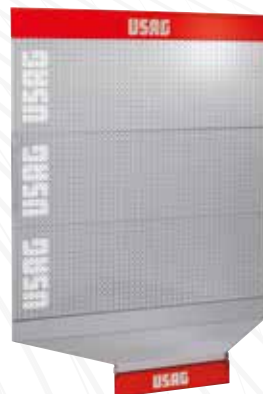

### 6001 B

**U60010012**

Display stand, closed  
corner

- Kit with 78 hooks and supports included
- Structure without uprights



## 6001 C

**U60010013**

Display stand, open corner

- Structure without uprights



## 6001 D

**U60010014**

Display stand, back for initial element

- Kit with 78 hooks and supports included
- Structure without uprights

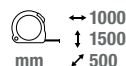

## 6001 AS

**U60010011**

Display stand, consecutive element

- Kit with 78 hooks and supports included
- 1 upright included

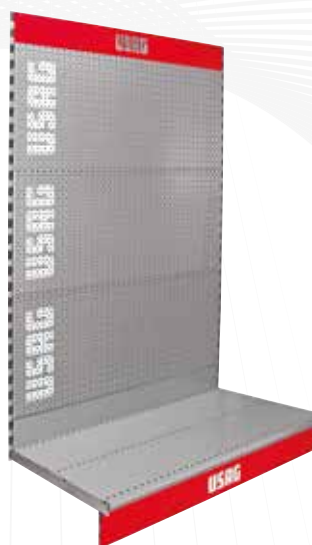
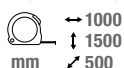

## 6001 DS

**U60010015**

Display stand, back for consecutive element

- Kit with 78 hooks and supports included
- Structure without uprights

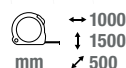

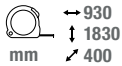

## 6002 TB1

**U60025011**

Showcase

- Double door with lock
- Corners in Aluminium
- Internal lighting with double halogen spot-light
- Lower cabinet for stocks with double door and lock
- Built-in wheels
- Kit with 50 hooks and glass middle shelf included

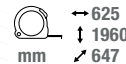

## 6002 TE

**U60025033**

Display totem

- Two-faced perforated surface
- Kit with 40 hooks included
- 4 pivoting wheels

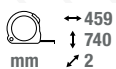
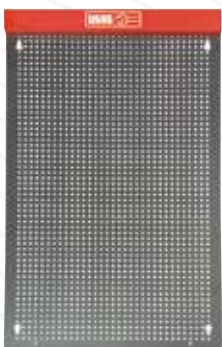

## 545 PT

**U05450001**

Perforated panel

- Hole diameter 5 mm
- Enamelled sheet steel; thickness 2 mm
- Combinable with screw-hooks code 552÷559
- Combinable with hooks for display stands

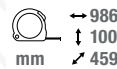

## 6000 PB

**U60000007Q**

Drawer

- To be used with linear elements 6000 and 6001



## 6000 E

**U60000016**

Non-perforated wall 2 m height

- To be used to cover back-side of linear elements

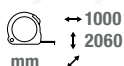

## 6001 E

**U60010016**

Non-perforated wall 1,5 m height

- To be used to cover back-side of linear elements

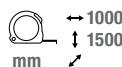

## 6002 A

**U60020010**

Cabinet for stocks

- Wooden structure
- Supplied already assembled with base

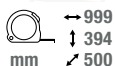

## 6002 B1

**U60020011**

High showcase

- Supplied disassembled
- Structure in Aluminium
- Glass shelves included
- Double sliding door with lock
- To be used with linear elements 6000

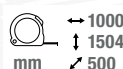

## 6002 B3

**U60020013**

Small showcase

- Supplied disassembled
- Structure in Aluminium
- Glass shelves included
- Double sliding door with lock
- To be used with linear elements 6000 and 6001

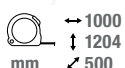

## 6002 D

**U60020015**

Sides for news

- To be put on linear elements 6000
- Highlights the exposed products
- Composed by 2 sides in red plexiglass

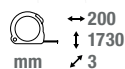



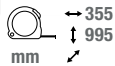

## 6002 DA

**U60020016**

Coat hanger bar

- To be put on linear elements

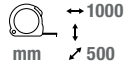

## 6002 EA

**U60020021**

Linear shelf

- Supplied with supports for hanging
- To be used with linear elements 6000 and 6001

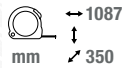

## 6002 EB

**U60020022**

Closed corner shelf

- Supplied with supports for hanging
- To be used with closed corner elements 6000 B and 6001 B

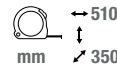
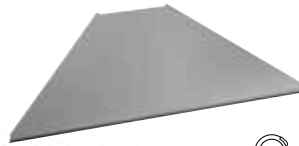

## 6002 EC

**U60020023**

Open corner shelf

- Supplied with supports for hanging
- To be used with open corner elements 6000 C and 6001 C



## 6002 FB1

**U60020027**

Separators kit

- For bases and shelves
- To be used with linear shelves 6002 EA

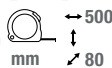

## 6002 FB2

**U60020028**

Separator

- For bases and shelves
- To be used with linear shelves 6002 EA

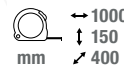

## 6002 H1

**U60020055**

Shelf for sockets (empty)

- Plexiglass cover to prevent shoplifting
- Lock with key
- 42 movable dividers included
- To be used with linear elements 6000 and 6001



## 6002 PA

**U60020071**

Platform for roller cabinets, small

- Supplied with 6 adjustable legs

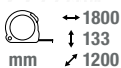
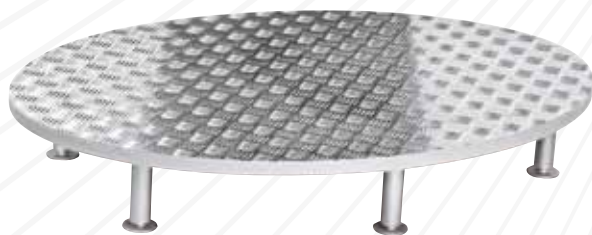

## 6002 PB

**U60020072**

Platform for roller cabinets, large

- Supplied with 6 adjustable legs



## 6002 MA

**U60020061**

Counter display stand

- Rear side with double door
- Double locking



## 6002 MB

**U60020062**

Counter display stand with front glass

- Rear side with double door
- Double locking

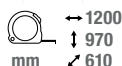

## 6002 MC

**U60020063**

Counter display stand with front and upper glass

- Rear side with double door
- Double locking



## 571 G

Simple hooks

∅ mm	L mm	Code
3,5	100	U05710301
3,5	150	U05710302
4	100	U05710303
4,8	150	U05710304
4,8	200	U05710305



## 571 GA

Double hooks

∅ mm	L mm	Code
12	100	U05710311
12	160	U05710312
20	140	U05710313
20	200	U05710314



## 571 GB

Special hooks for pliers

∅ mm	Code
60	U05710321
60	U05710322
65	U05710323
65	U05710324



## 571 GC

Ring double hooks

∅ mm	L mm	Code
10	150	U05710331
13	150	U05710332
20	250	U05710333



## 6002 GD

Supports for open-jaw double ended wrenches

∅ mm	dimensione mm	Code
10 (6÷14 mm)	143x50	U60020047
10 (12÷23 mm)	143x50	U60020048
5 (17÷36 mm)	143x50	U60020049

## 571 FK50

**U05710453**

Product tag



# MAGNETIC SUPPORT FOR DISPLAY WALLS

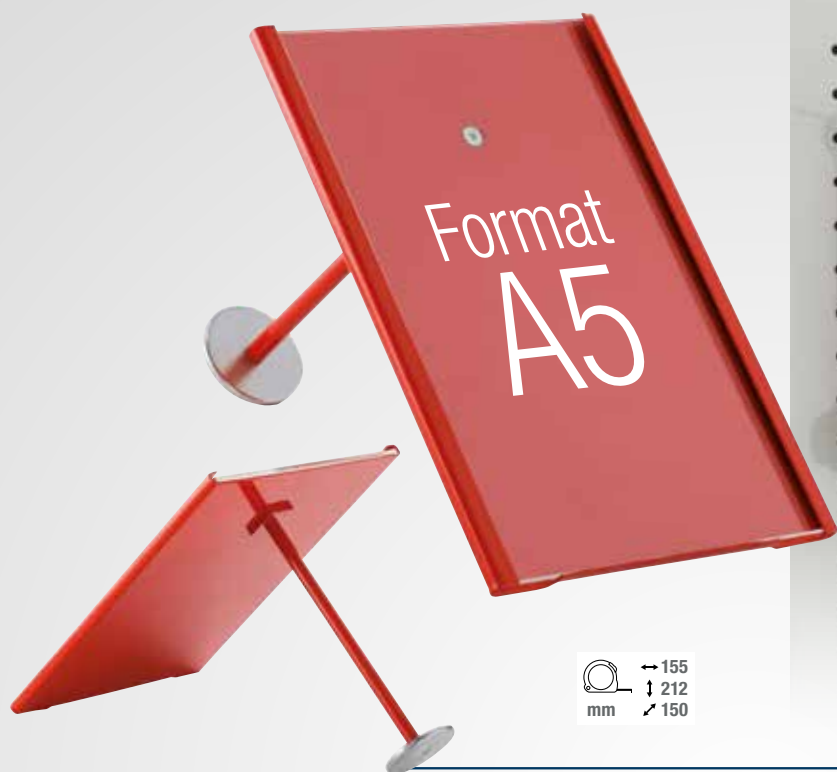

## 6002 GM

**U60025034**

- To highlight the main advantages of the best products on display
- Cardboard seat with Plexiglas protection, A5 format
- Vano porta cartoncino con protezione in Plexiglass, formato A5

091 and 091 D, 150 AX, 207 E, 236 K, 237 A, 280 T, 285, 285 KA, 324, 382 F, 294 AD, 443 N, 928 AC1 1/2", 929 PC1 1/2", 943 PC1 1/2"



## 6002 GMC

**U60025040**

Kit of 8 cards for magnetic support

- Two-sided printing in Italian and English

The images shown in this brochure are not binding.  
Stanley Black & Decker Italia S.r.l. reserves the right to change the technical characteristics of its products at any time.

**Stanley Black & Decker Italia S.r.l.**

Via Volta, 3 - 21020 - Monvalle (VA)  
Tel. +39 0332 790 111 - info.mv@usag.it

**usag-tools.net**

